

SHAREATE



Single Roller Bit



SHAREATE
SHAREATE TOOLS LTD.

Marketing Office

Add : No 6, Weixi Road, Suzhou Industrial Park, Jiangsu, China

Post Code : 215121

Tel : 86 (512) 6285 1657

Fax : 86 (512) 6285 1661

E-mail : shareate-sz@shareate.com



SHAREATE TOOLS LTD.



COMPANY INTRODUCTION

Shareate Tools Ltd., located in Suzhou Industrial Park, is a professional company engaged in the R&D and manufacturing of cemented carbide products and rock drilling tools. It has two major manufacturing bases in Qianjiang and Suzhou, fitted with advanced producing and testing equipment, they are R&D and manufacturing bases of cemented carbide products and rock drilling tools with leading domestic technology level and increasing scale.

The company has strong scientific and technological innovation ability, and has formed systematic independent intellectual property rights and technologies. In 2008, the company passed the API qualification certification for the first time and has been granted the ISO9001 quality system certification in the same year. The company has established an independent R&D center, which has been recognized as "Jiangsu Province efficient rock drilling tool engineering technology research and development center" and "Jiangsu Province Enterprise Technology Center". The company and Nanjing University of Aeronautics and Astronautics jointly build "Jiangsu Province enterprise graduate workstation", which provides a solid foundation for the enterprise's continuous innovation.

The company adopts advanced flexible manufacturing system and builds a flexible production line with CNC machining center as the main body, laying a solid foundation for manufacturing first-class quality products.

The company's main products include: cemented carbide products such as cemented carbide for oil drilling, cemented carbide for mining, matrix for diamond composite chip, nozzle for oil drilling bit, and rock drilling products such as tricone bits, single roller bits, trenchless drilling bits, roller cutters, DTH hammer, hammer bits, etc. Our products are exported to South Korea, the United States, Canada, Australia, South America, Russia and more than 20 countries and regions, highly liked and praised by the customers at home and abroad.

Introduction of Products

SHAREATE TOOLS LTD., aiming at complexity and variability of rotary drill bit market, has developed a series of rotary drill bits with single roller, two roller and tricone roller, which can adapt to the compressive strength from strongly weathered rock to slightly aerated rock from 50MPa to 150MPa, to meet customer's specific need to the greatest extent, also can customize bit model according the market requirements.

1 Basic structure of single roller bit

As a component, the single roller bit is alternately installed on the thin-wall shaft to form a rotary drilling. Among them, the two and three toothed wheels need to be welded to achieve the full coverage of the broken ring.

The single roller bit is composed of a single cone and a lug matched by a bearing. According to different strata and construction requirements, different cutting structures can be selected; wear resistant carbide are welded and cemented carbide inserts are inserted on the back of the lug.

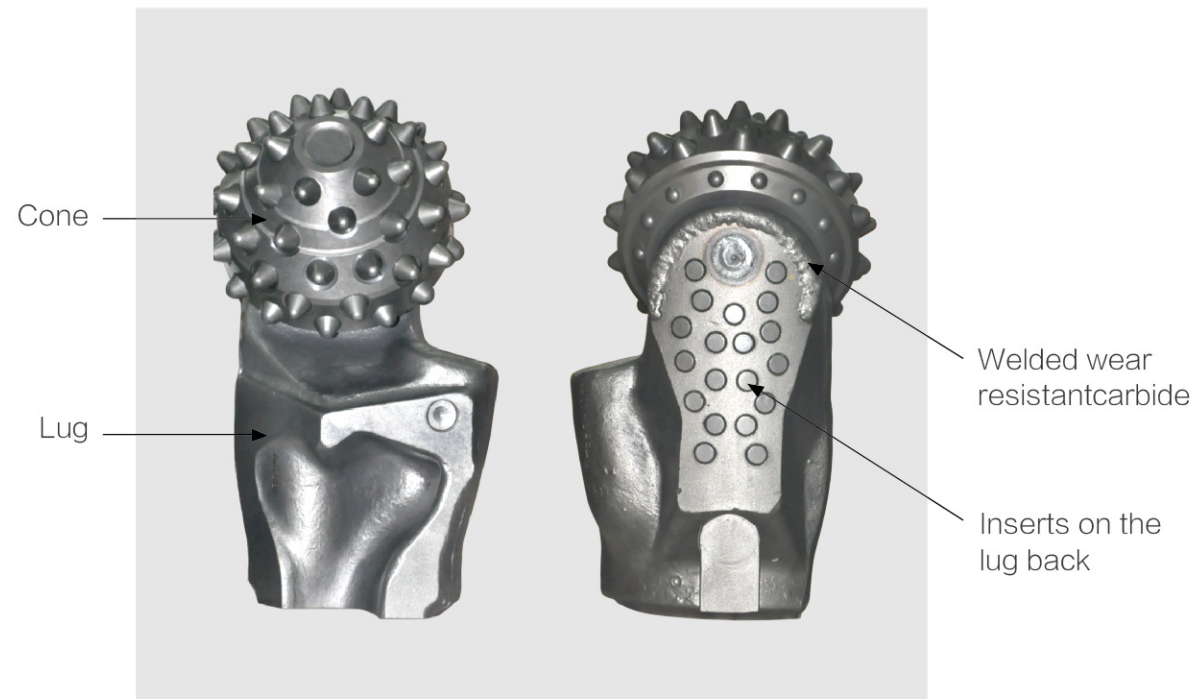

2 Working principle

Rotary drilling rig drives shaft to rotate and exert positive pressure so that the rotary drilling bit can impact, roll and shear the rock, crush the rock to form a crushing ring zone, and then break the middle pillar by the swing of the shaft, and take the broken pillar out to form a hole.

3 Bit naming

Shareate single roller bit product model is divided into four sections: drill bit diameter code, drill bit series code, IADC code, and additional features code. Using 8 1/2 YHA617Y as an example:

8 1/2	YHA	617	Y
Drill bit size	Drill bit series	IADC code	Additional features

3.1 Drill bit size

Displayed in numbers to indicate the diameter in inches.

3.2 Series code

Displayed by 3 English letters.

- The first letter represents the type of bit: Y represents single cone bit, T represents two cone bit, M represents tricone bit.
- The second letter represents the bearing of bit, H represents journal bearing, G represents roller bearing.
- The third letter represents the seal of bit, A represents O-type rubber seal, V represents flat rubber seal.

3.3 IADC code

It consists of three digits, the first digit represents the type of drill bit cutting structure and formation hardness, the second digit is the formation classification number, and the third digit is the bearing and sealing characteristics code.

- The first digit ranges from 4 to 8, which designates soft formation, medium-soft formation, medium-hard formation, hard formation and extremely hard formation.
- The second digit: 1、2、3、4 (classification of formation, Higher values indicate higher formation hardness)
- The third digit: Shareate usually uses 5 (sealed roller bearing), 7 (sealed journal bearing).

3.4 Additional feature code

Additional characteristic code reflects the special structure of the rotary drill bit. The optional additional characteristic code for shareate rotary drill bit is shown in the table below.

Code	Additional feature
F	Cone auxiliary carbide protection
G	Specific lug back strengthening
W	Shirttail hard facing
X	Wedge inserts
Y	Ovoid inserts

The Feature of Structure

1 Bearing structure

Shareate rotary drill bit mainly uses sealed journal bearing, which consists of bore of cone shaft, Journal of palm of tooth, steel ball and rubber sealing ring (see figure below). According to a lot of experience in using rotary drill bit, the bearing has stable structure, strong bearing capacity and low risk of losing the cone, and is suitable for various hardness and lithology formations.

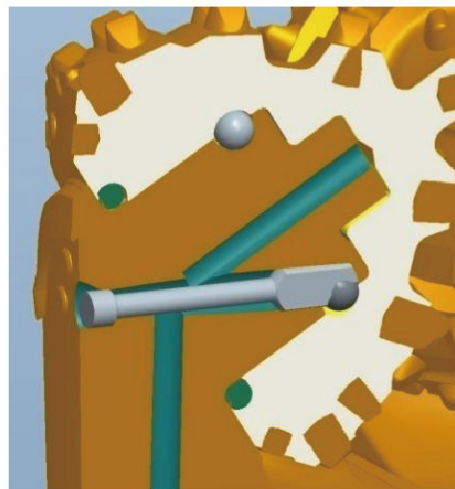

2 Cutting structure

The cutting structure has perfect support of software and hardware. The cutting structure design is precise and the tungsten carbide inserts have excellent performance. They can cope with different hardness and lithology formation and provide customers with high efficiency and low cost drilling program.

2.1 Tungsten carbide inserts distribution and selection

Through the computer simulation system, the situation that the drill bit crushes the rock at the bottom of the well is simulated, the most reasonable distribution of the tungsten carbide inserts is carried out, the working load of each tungsten carbide inserts is balanced, and the most suitable insert shape and material are selected which improve the life and drilling efficiency, further reduce the drilling cost and cycle.

Shareate owns independent R & D and production lines of tungsten carbide inserts, leading sintering and pressing processes and equipment in China. The company also has advanced tungsten carbide inserts testing equipment to ensure the quality is stable. Shareate inserts with abundant insert profile and optional materials, which are superior performance and stable quality. They provide the best and most stable quality tungsten carbide inserts for rotary cone bits.

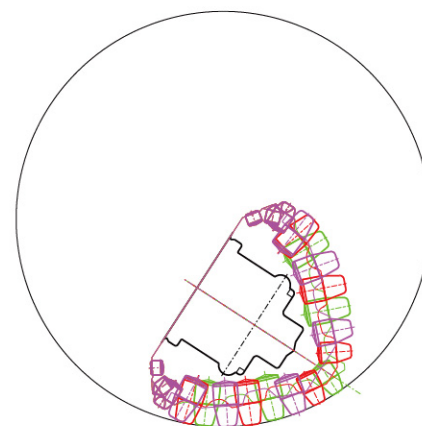

2.2 Band width and installation angle

According to the different wall thickness, diameter of wellbore and the requirements of drilling engineering, the bandwidth and installation angle of rotary drill bit are selected differently. Reasonable bandwidth and installation angle can completely cover the cutting ring belt at the bottom of the well and uniform stress distribution of inserts can greatly improve the service life, which directly affects drilling efficiency and quality.

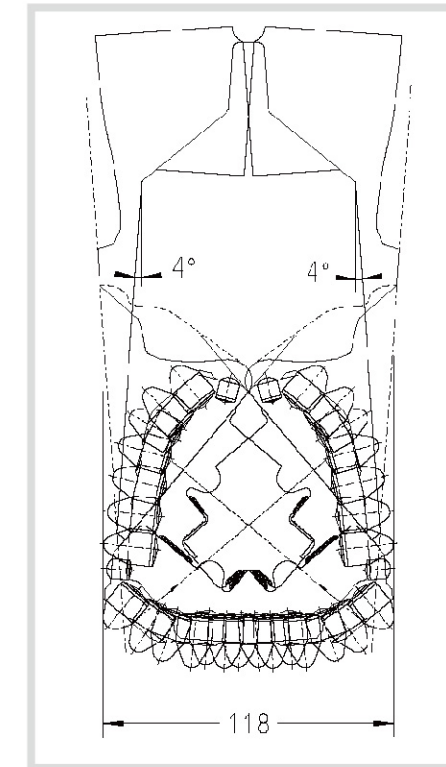

3 Lug structure

There are three options for the lug, i.e. lug plain type, straight handle welded type and straight handle removable type.

Common type

It is installed on the well bore by welding and is the most widely used structure in China at present. The lug plain type is solidly welded and not easily loosened, but the amount of welding will have a high temperature effect on the drill bit performance and inaccurate angle and position control of welding.



◎ Straight handle welded type

It is installed on the well bore by welding, and it is a gradually transformed structure in China at present. The palm of the structure is solidly welded and not easily loosened. The regular shape welding quantity is relatively small and the control accuracy of welding angle and position is improved.



◎ Straight shank removable type

Is a new installation method, which welds the matching fixture to the well bore and then fastens the rotary drill bit to the well bore by bolting. The palm dis-assembly and replacement of the structure is efficient, and the installation dimension and angle control are accurate. However, pre-welding fixture is required, and the matching fixture also needs to be replaced after wear, and the fixture can not adapt to all manufacturers' rotary drill bit.

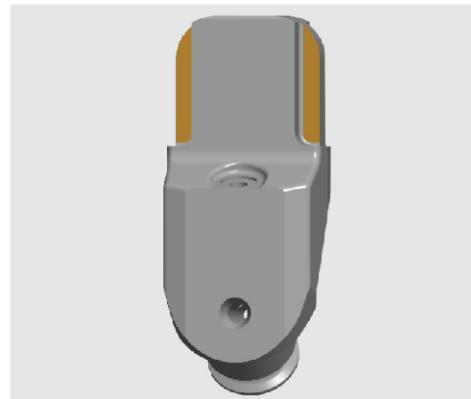

4 Lug structure

Lug back is protected by welding carbide layer and inserts, both sides of lug are welded with protection wear-resistant carbide layer to reduce the wear of cuttings to the bit.



8 1/2 YHA617Y Z01

• Application

50 ~ 130 MPa, Medium, breeze granite, limestone, dolomite, gravel etc. Medium and high compressive strength formation, strong homogeneity, medium and low abrasive formation.

• Feature

IADC Code:	6-1-7
Bearing:	Journal bearing
Sealing:	O-type rubber seal
Cutting structure:	Conical
Rows/Qty:	7/52
Shirrtail/Lug	Welding carbide & adding inserts



• Crashing rock width

114 ~ 118mm

• Recommend drilling pressure

Pull-down on the Cylinder: 20—30 T (maximum pull-down on every single cone bit: 5-6 T)

• Operating suggestions

Rock formation	Recommended Drilling Pressure	Recommend ROP	
		Hole depth (m)	Rotation Speed (RPM)
Medium hard (50-100Mpa)	20-30t	0.8-1.5	112-16
		1.5-2	10-12
		2-2.5	6-10
		2.5-2.8	3-6
hard (80-150Mpa)	20-35t	0.8-1.5	10-12
		1.5-2	8-10
		2-2.5	5-8
		2.5-2.8	2-5

* Note: in the same parameter range, if the cylinder diameter is larger, then rotation speed will be lower. The rated pull-down on single cone bit is 5-7 T, rated speed is 60-100rpm.

9 YHA637 Z01

• Application

80 ~ 150MPa, Granite, basalt, quartz porphyry, gravel, etc. Medium and high compressive strength formation, strong formation homogeneity, mixed formation, high abrasive formation.

• Feature

IADC Code:	6-3-7
Bearing type:	Journal bearing
Sealing:	O-type rubber seal
Cutting structure:	Conical
Rows/Qty:	6/42
Shirttail/Lug	Welding carbide & adding inserts



• Crashing rock width

114 ~ 120mm

• Recommend pull-down

Pull-down on the Cylinder: 20-35 T (maximum pull-down on every single cone bit: 5-6 T)

• Operating suggestions

Rock Formation	Recommend Pull-down	Recommend ROP	
		Hole depth (m)	Rotation Speed (RPM)
Medium hard (50-100Mpa)	20-30t	0.8-1.5	12-16
		1.5-2	10-12
		2-2.5	6-10
		2.5-2.8	3-6
Hard (80-150Mpa)	20-35t	0.8-1.5	10-12
		1.5-2	8-10
		2-2.5	5-8
		2.5-2.8	2-5

* Note: in the same parameter range, if the cylinder diameter is larger, then rotation speed will be lower. The rated pull-down on single cone bit is 5-7 T, and rated speed is 60-100rpm.

Bit Manufacture

Shareate Corporation adopts advanced flexible manufacturing system to build a production line with CNC machining center as the main body. The company has advanced heat treatment, welding and other special process equipment, high-automation equipment such as welding robot and painting robot, as well as high-precision inspection equipment such as three-coordinate tester, projector, electron microscope scanner and grating tester.

Advanced production and testing equipment, as well as excellent quality system, lay a solid foundation for manufacturing first-class quality rotary drill bit.



Users Case Study



• Construction site in Fujian Putian



• Construction site in Wuhan Jiangxia



• Construction site in Shenzheng Nanshan



• Construction site in Suzhou Mudu



• Construction site in Chongqing

On-site Service

Shareate provides a full range of high quality field on-site services, including drill bit selection, short delivery, installation guidance, product improvement, and technical services in case of construction abnormalities.

According to different construction conditions, Shareate recommends the most reasonable installation method of rotary roller bit, provides installation auxiliary tools, and recommends effective measures to control welding temperature, so as to improve drilling efficiency, shorten the construction period of customers and reduce construction cost.

1 Bit selection

According to our vast experience, the single roller cone bit has the most stable performance, the most widely applicable formation, and high drilling efficiency. The following two kinds of roller cone bits are recommended, and we can provide targeted products according to customers' requirements.

Bit specification		Apply formation
8 1/2	YHA617Y	50 ~ 130MPa, Medium, breeze granite, tuff, limestone, dolomite, gravel, etc. Medium and high strong compressive strength formation, high homogeneity formation, medium and low abrasive formation.
9	YHA637	80 ~ 150MPa, breezy granite, basalt, quartz porphyry, tuff, gravel, etc. Medium and high compressive strength formation, high homogeneity formation, mixed formation, high abrasive formation.

2 Wellbore diameter and quantity of installations

According to the different construction pile diameter to select the appropriate wellbore diameter, as well as the quantity of rotary cone bit installation, it is recommended to choose according to the following table:

Wellbore diameter (m)	0.6	0.8	1	1.2	1.5	1.8	2	2.2	2.5	2.8
Quantity of Installations (pieces)	4	6	8	10	12	14	16	18	20	22

3 Bit assembly

Rotary roller bit is installed by alternately welding the positive and negative side to the wellbore cut. During the installation process, it is necessary to select the appropriate installation bandwidth and angle according to the size of the wellbore and the cutting structure of the rotary cone bit, and adopt the installation auxiliary tools professionally designed by Shareate, which can effectively guarantee the accuracy and consistency of the bandwidth and installation angle.

3.1 Installation Tools

Shareate has designed two kinds of rotary cone bit installation tools for customers. The first one is suitable for different bandwidth and installation angle. The tool has a wide range of use. The second is suitable for fixed bandwidth and installation angle, this tool operation is simple and efficient.

Installation tools are necessary for the welding of rotary roller bit, which can ensure the stability and consistency of the bit welding quality, avoid the occurrence of individual bit welding position is not in place, salvage, cutting and rewelding after early failure, and delay the construction period.

• Suitable for different bandwidth and installation angles

The outer circle of the wellbore and the back of the lug back are used as the positioning plane, and the installation Angle is controlled by the angle meter. After proper adjustment, it is fixed by welding.

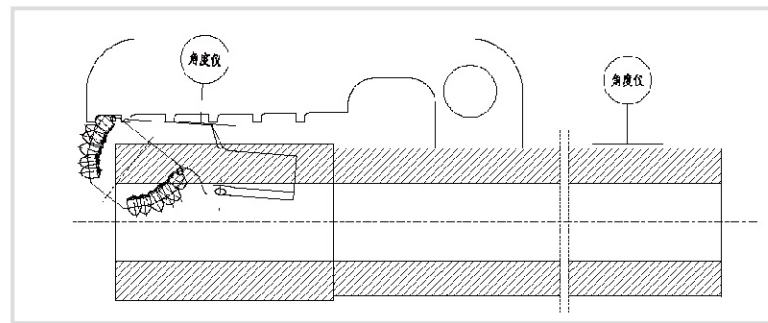

• Suitable for fixed bandwidth and installation angle

The design principle is the same as the first one. The tool bevel is processed into the required installation angle in advance. The advantage lies in the simple operation and accurate control without the help of angle meter.

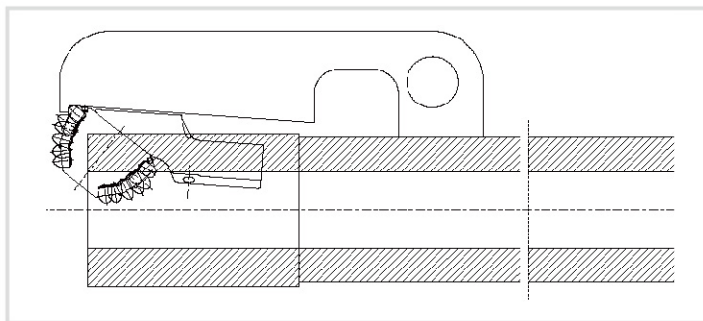

3.2 Welding temperature control

High temperature will occur in the welding process, but the temperature of sealing ring and grease in the bearing should not exceed 100°C, otherwise it will affect the bearing performance. Therefore, cooling measures should be taken in the welding process and welding methods should be paid attention to.

• Cooling measures

According to the site construction environment and equipment conditions, Shareate recommends two easy ways cooling methods: one is water pipe water cooling, another way is wet towel wrapping cooling.



• Welding method

The use of layered welding method, each bit welding in 3-4 times by a layer of welding one time. Each layer of welding must be accompanied by water injection cooling. If the water boils during the welding (or if the temperature marker is used to draw lines on the drill bit and the lines change color after exceeding the specified temperature), the welding shall be stopped immediately and the wet towel shall be used for cooling. Weld the other bits first, and then finish the welding after the temperature of the first bit drops.

• Disclaimer

Installation angle and bandwidth as well as the welding temperature shall be strictly controlled when the rotary cone bit is welded. If welding is not carried out in accordance with the requirements at the construction site and part of the rotary cone bit fails early, Shareate will arrange professional technicians to provide on-site service, cause analysis and communication. If it is proved that there are unreasonable operations not in accordance with the requirements during the welding process, Shareate will not be responsible for the losses caused thereby.